

Emerald QE-256/30 AAA

256-Channel
Inkjet Printhead



Emerald QE-256/30 AAA

Features:

- 30 picoliter nominal drop size
- 256 individually addressable, inline nozzles
- Incorporates VersaDrop™ binary and grayscale jetting modes
- Excellent channel-to-channel uniformity
- High frequency continuous operation
- Precise alignment features facilitate drop-in replacement
- Lightweight with thin profile
- Supports UV-curable, solvent and aqueous-based inks
- Integral temperature sensor
- Dual-ported with minimal wetted surface area
- OEM accessible non-volatile memory area for tracking purposes
- Easy to integrate

The Performa™ Emerald QE-256/30 AAA printhead combines precise jetting with versatile grayscale operation. Using a durable field proven nozzle plate, its lightweight, thin-profile and configurable design supports a wide range of ink types with broad operational latitude to accommodate variations in jetting properties making this printhead ideal for scanning printer architectures.

Dimatix continues building upon its long history of excellent dot placement accuracy, channel-to-channel uniformity, low cross talk, and high-frequency/high-productivity with the Q-Class Emerald printhead family.

The Emerald QE-256/30 AAA printhead features 256 independent channels, arranged in a single row of nozzles at 100 dots-per-inch spacing. It is designed to eject adjustable 30 to 80 picoliter drops in binary jetting mode or a 30-picoliter fundamental drop in grayscale mode. This is done at a nominal 8-meter per second drop velocity when jetting fluids in the 10 to 14 centipoise range.

Dimatix' breakthrough VersaDrop™ jetting technology is featured within the Emerald QE-256/30 AAA printhead. It allows unparalleled flexible modes of operation including adjustable binary drop size and grayscale capability at unprecedented throughput rates.

The rugged, field proven material set selected for the Emerald QE-256/30 AAA printhead deliver long service life and consistent output.

Robust field proven metal nozzle plate technology provides precise drop placement accuracy of a wide variety of ink types, including UV-curable, solvent and aqueous, plus the broadest operational latitude to accommodate variations in ink jetting properties.

Precision registration points have been added to the printhead to provide absolute reference to the nozzles to within a few microns. This makes it possible to nest printheads together for high packing densities.

Shared physical features and identical interfaces as other Q-Class products allow the Emerald QE-256/30 AAA to be intermingled with the same or complementary printhead models to create a multitude of single and multiple-color configurations.

Each 256-channel Emerald printhead is offered with an integral temperature sensor and a configurable, dual-ported fluid interface comprised of O-ring face mounts or barbed fittings to facilitate fast flushing or recirculation of inks.

Printhead operational temperature can be up to 90° C. The driver chip is double buffered to support the Emerald QE-256/30 AAA high-speed jetting capability.



www.dimatix.com

Parameter

Number of addressable jets
 Print width
 Nozzle spacing
 Typical jet straightness, 1 sigma*
 Typical drop velocity variability, 1 sigma*
 Ink operating temperature range
 Fluid viscosity range (at jetting temperature)
 Compatible jetting fluids

BINARY OPERATION:

Adjustment for drop size
 Productivity

GRAYSCALE OPERATION:

Number of levels
 Fundamental drop size
 Productivity

OEM accessible non-volatile memory

*at constant frequency

Emerald QE-256/30 AAA

256
 64.77 mm [2.550 in.]
 254 microns [0.010 in.] (100 dpi)
 1.5 mrad [0.085°]
 5%
 up to 90° C [194° F]
 8 - 20 cP (10 - 14 cP recommended)
 UV curable, organic solvents, and aqueous inks

30 - 80 picoliters

Drop Size	Maximum Frequency
30 pl	33 kHz
50 pl	20 kHz
80 pl	20 kHz

up to 4

30 picoliters

Largest Drop Size	Maximum Frequency
50 pl	20 kHz
80 pl	12 kHz

Two 256-bit pages, write once

Physical Characteristics

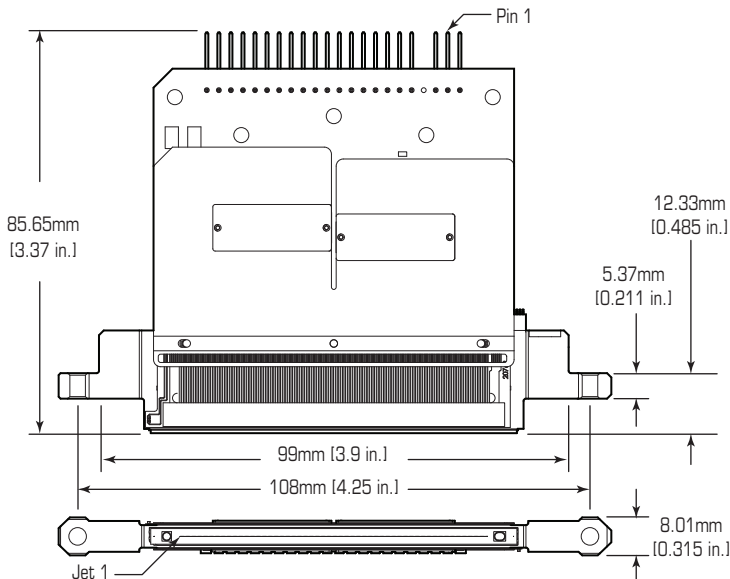

Jetting Characteristics

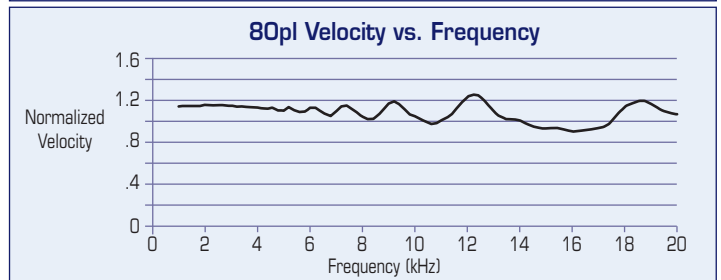
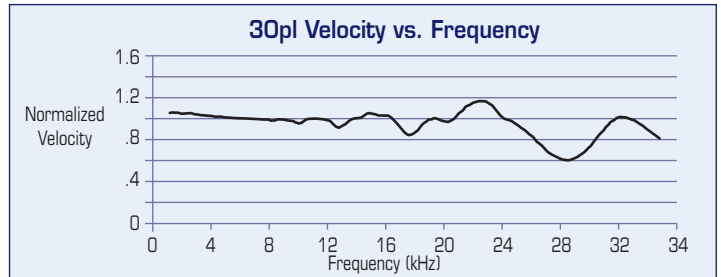

Product data presented above are for guideline purposes only. For design and engineering work using this product, please contact Dimatix Technical Support for the appropriate Product Manual containing full Product Specifications.



Corporate Office:
 FUJIFILM Dimatix, Inc.
 2230 Martin Avenue
 Santa Clara, CA 95050
 USA

Tel: (408) 565-9150
 Fax: (408) 565-9151
 Email: info@dimatix.com

New Hampshire Facility:
 FUJIFILM Dimatix, Inc.
 109 Etna Road
 Lebanon, NH 03766
 USA

Tel: (603) 443-5300
 Fax: (603) 448-9870
 Email: info@dimatix.com

Japan Office:
 Advanced Marking Business Division
 FUJIFILM Corporation
 Midtown West, 7-3, Akasaka 9-Chome
 Minato-ku, Tokyo 107-0002
 Japan

Tel: +81 3 6271 1091
 Fax: +81 3 6271 1165
 E-mail: front.ambd@fujifilm.co.jp

European Office:
 Tel: +44 7739 863 505
 Fax: +44 870 167 4328
 Email: euro@dimatix.com

Korean Office:
 Tel: +82 2 6242 6012
 Fax: +82 2 6247 6012
 Email: korea@dimatix.com

China Office:
 Email: china@dimatix.com